

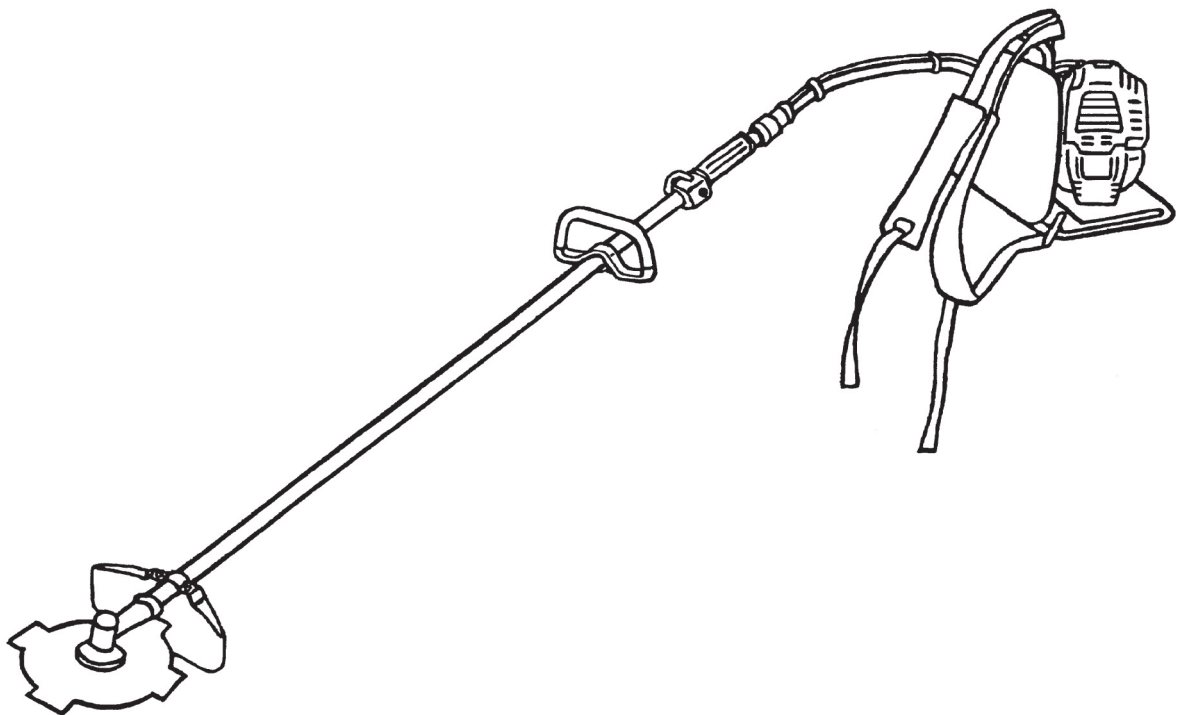

Backpack Brushcutter

EBH340R

INSTRUCTION MANUAL



Warning

Read this instruction manual carefully before putting the brushcutter into operation and strictly observe the safety regulations!

Preserve instruction manual carefully!

Thank you very much for selecting the MAKITA brushcutter. We are pleased to be able to you the MAKITA brushcutter which is the result of a long development programme and many years of knowledge and experience. Please read, understand and follow this booklet which refers in detail to the various points that will demonstrate its outstanding performance. This will assist you to safely obtain the best possible result from your MAKITA brushcutter.



Table of Contents

Page

Symbols..... 2
 Safety instructions 3-6
 Technical data..... 7
 Designation of parts..... 8
 Assembly of engine and drive shaft..... 9-10
 Mounting of handle..... 11
 Mounting of protector..... 11
 Mounting of cutter blade..... 11
 Before start of operation..... 12-13
 Points in operation and how to stop 14-15
 Resharpener the cutter blade 15
 Servicing instructions 16-18
 Storage 19-20
 Troubleshooting..... 21

SYMBOLS

It is very important to understand the following symbols when reading this instructions manual.

	Read instruction Manual		Wear protective helmet, eye and ear protection
	WARNING/DANGER/CAUTION		Top permissible tool speed
	Forbidden		Fuel (Gasoline)
	Keep distance		Engine-Manual start
	Flying object hazard		Emergency stop
	No Smoking		First Aid
	No open flame		Recycling
	Protective gloves must be worn		ON/START
	Kickback (for brushcutter only)		OFF/STOP
	Keep the area of operation clear of all persons and pets		

SAFETY INSTRUCTIONS

General Instructions

- To ensure correct and safe operation, the user must read, understand and follow this instruction manual to assure familiarity with the handling of the brushcutter. Users insufficiently informed will risk danger to themselves as well as others due to improper handling.
- It is recommended only to loan the brushcutter to people who have proven to be experienced with brushcutters. Always hand over the instruction manual.
- Use brushcutters with the utmost care and attention.
- First-time users should ask the dealer for basic instructions to familiarize oneself with the handling of an engine powered cutter.
- Children and young persons aged under 18 years must not be allowed to operate the brushcutter. Persons over the age of 16 years may however use the tool for the purpose of being trained only while under the direct supervision of a qualified trainer.
- Use brushcutters with the utmost care and attention.
- Operate the brushcutter only if you are in good physical condition. Perform all work conscientiously and carefully. The user has to accept responsibility for others.
- Never use the brushcutter while under the influence of alcohol or drugs.
- Do not use the unit when you are tired.
- **Save these instructions for future referral.**

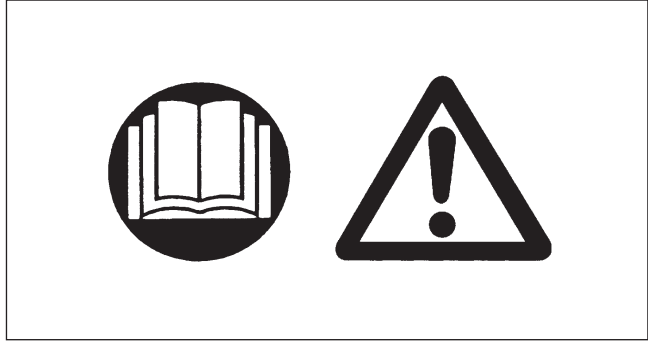

Personal protective equipment

- The clothing worn should be functional and appropriate, i.e. it should be tight-fitting but not cause hindrance. Do not wear jewelry, clothing or long hair which could become entangled with bushes or shrubs.
- In order to avoid head-, eye-, hand- or foot injuries as well as to protect your hearing the following protective equipment and protective clothing must be used during operation of the brushcutter.
- Always wear a helmet when working in the forest. The protective helmet (1) is to be checked at regular intervals for damage and is to be replaced at least every 5 years. Use only approved protective helmets.
- The visor (2) of the helmet (or approved goggles) protects the face from flying sticks, stones or other object. During operation of the brushcutter always wear goggles, or a visor to prevent eye injuries.
- Wear adequate noise protection equipment to avoid hearing impairment (ear muffs (3), ear plugs etc.), especially during extended work periods.
- The work overalls (4) protect against flying stones and splinters. We strongly recommend that the user wear work overalls.
- Special gloves (5) made of thick leather are part of the prescribed equipment and must always be worn during operation of the brushcutter.
- When using the brushcutter, always wear sturdy shoes (6) with a non-slip sole. This protects against injuries and ensures good footing.

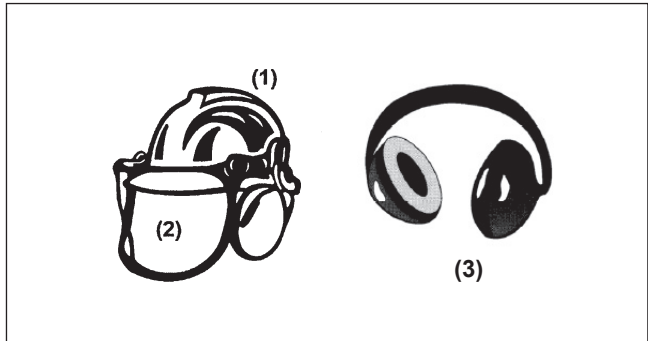

Starting up the brushcutter

- Please make sure that there are no children or other people within a working range of 50 ft. or 15 meters, also pay attention to any animals in the working vicinity.
- **Before operating, always check that the brushcutter is safe for operation:**
 Check the security of the cutter blade. Be sure the blade mounting nut is firmly secured. The throttle lever should be checked for smooth and easy action. Check for proper functioning of the throttle lever lock. The cutter blade must not rotate during idling.
 Consult idle adjustment instructions on page 15. Check for clean and dry handles and test the function of the STOP switch. Keep handles free of oil and fuel.
- Before operation, check and follow local; regulations concerning sound level and hours of operations.
- Only start the brushcutter positioned on the ground.
- Do not start it on the back.

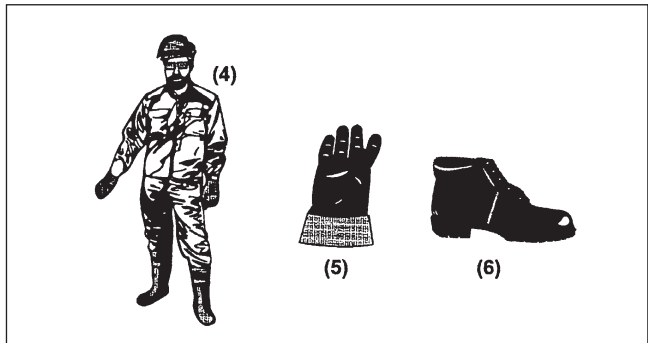

Start the brushcutter only in accordance with the instructions.

Do not use any other methods for starting the engine!

- Use the brushcutter and the tools supplied only for applications specified.
- Start the brushcutter engine only after the entire tool has been assembled. Operation of the tool is permitted only after all the appropriate accessories are attached!
- Before starting, make sure that the cutter blade will not contact any objects such as branches, stones, etc.
- The engine is to be stopped immediately if there are any engine problems.
- Should the cutter blade hit stones or any other objects immediately stop the engine and inspect the cutter blade.
- Inspect the cutter blade at frequent regular intervals for damage (detect hairline cracks by means of a tapping-noise test).
- A familiar ringing sound should be heard.
- Operate the brushcutter only with the shoulder strap attached. It should be properly adjusted before putting the brushcutter into operation. It is essential to adjust the shoulder strap to the user's size to prevent fatigue occurring during use or loss of control of the tool. Never hold the tool with one hand during use.
- During operation always hold the brushcutter with both hands. Always ensure a safe, well-balanced footing.
- Operate the brushcutter in such a manner as to avoid inhalation of the exhaust gases. Never run the engine in enclosed rooms (risk of suffocation and gas poisoning). Carbon monoxide is an odorless gas. Always ensure there is adequate ventilation.
- Stop the engine when resting and when leaving the brushcutter unattended. Place it in a safe location to prevent danger to others, setting fire to combustible materials, or damage to the machine.
- Never lay down the hot brushcutter onto dry grass or onto any combustible materials.
- The cutter blade must be used with its appropriate guard. Never run the tool without this guard!
- All protective parts and guards supplied with the machine must be used during operation.
- Never operate the engine with a faulty exhaust muffler.
- Stop the engine during transport.
- During transport over long distances the tool protection included with the equipment must always be used.
- Put the brushcutter in upright position and fix it during care or truck transportation to avoid damage.
- When transporting the brushcutter, ensure that the fuel tank is completely empty, to avoid fuel leakage.

Refuelling

- To reduce the risk of fire and burn injury, handle fuel with care it is highly flammable. Stop the engine during refuelling, keep well away from open flame and do not smoke.
- Avoid skin contact with petroleum products. Do not inhale fuel vapor. Always wear protective gloves during refuelling. Change and clean protective clothing at regular intervals.
- Take care not to spill either fuel or oil. Always wipe unit dry before starting engine. Allow wet cloths to dry before disposing in proper, covered container to prevent spontaneous combustion.
- Avoid any fuel contact with your clothing. Change your clothing immediately if fuel has spilled on it (danger hazard).
- Inspect the fuel cap at regular intervals making sure that stays securely fastened.
- Carefully tighten the locking screw of the fuel tank. Change locations to start the engine (at least 10 ft. or 3 meters away from the place of refuelling).
- Never refuel in closed rooms. Fuel vapors accumulate at ground level (risk of explosions).
- Only transport and store fuel in approved containers. Make sure stored fuel is not accessible to children.
- Do not attempt to refuel a hot or a running engine.
- When mixing gasoline with two-stroke engine oil, use only gasoline which contains no ethanol or methanol (types of alcohol). This will help to prevent damage to fuel lines and other engine parts.

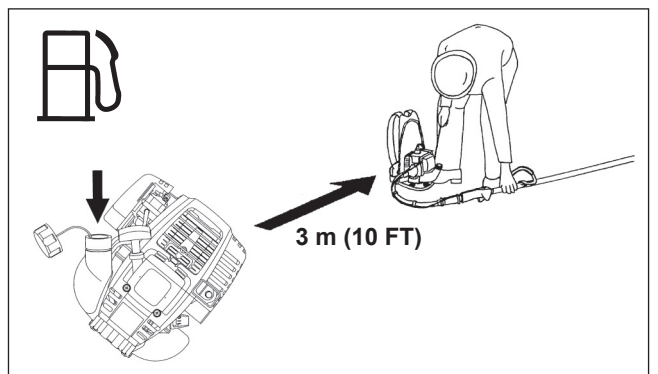
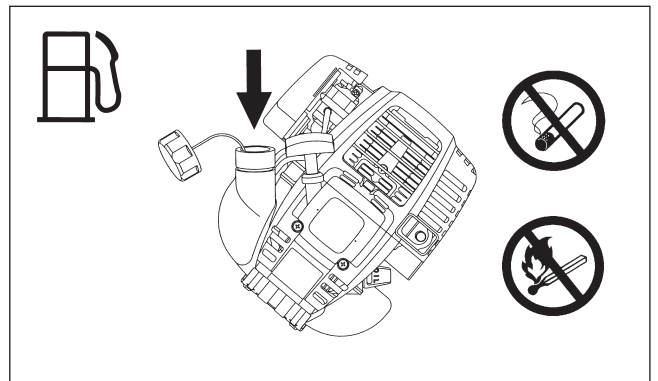
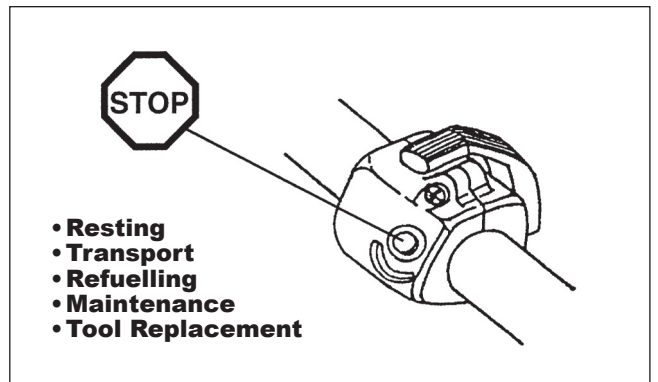
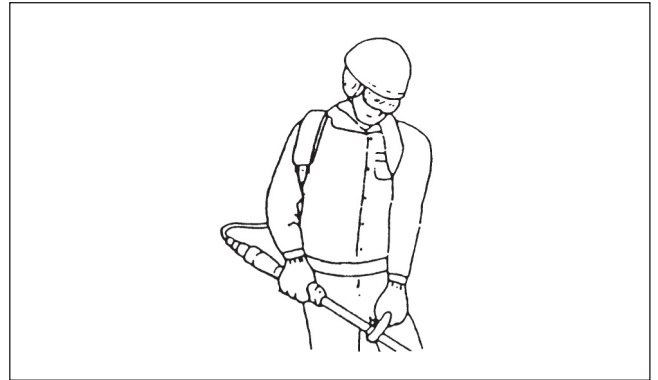
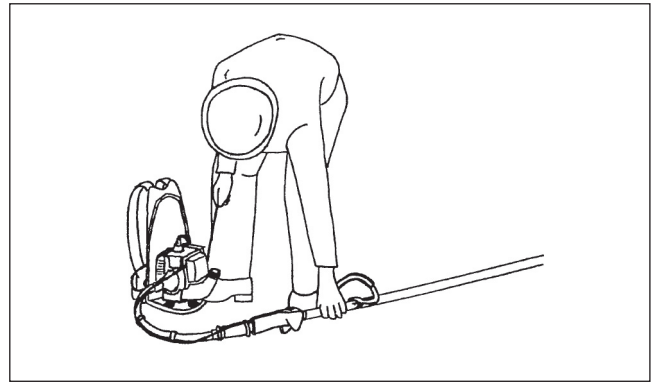

Method of operation

- Use the brushcutter only in good light and visibility. During cold seasons beware of slippery or wet areas, ice and snow (risk of slipping). Always ensure a safe footing.
- Do not overreach. Keep proper footing, balance and hand control of the unit at all times.
- Never cut above waist level.
- Never stand on a ladder while running the brushcutter.
- Never climb up into trees to perform any cutting operation with the brushcutter.
- Never work on unstable surfaces or steep terrain.
- Remove all objects such as stones, nails, broken glass, wire, etc. found within the working areas.
Foreign articles may damage the cutting tool, can cause dangerous kickbacks, or could be thrown about dangerously.
- Before commencing cutting the cutting tool must have reached full working speed.
- Never operate this tool while it is turned upside-down or when it is at an extreme angle.
- **WARNING! — The cutter area is still dangerous while the machine is coasting to a stop.**



Kickback

- When operating the brushcutter, uncontrolled kickback can occur.
- This particularly is the case when attempting to cut within a blade segment between 12 and 2 o'clock as viewed from the operator's position.
- Never touch this segment of the brushcutter to solid objects, such as bushes, stumps, trees, etc., with a diameter greater than 3 cm.
- The brushcutter will then be deflected at great force and speed with the potential risk of serious injuries.
- **Never operate the brushcutter using the blade segment between the 12 and 2 o'clock position.**

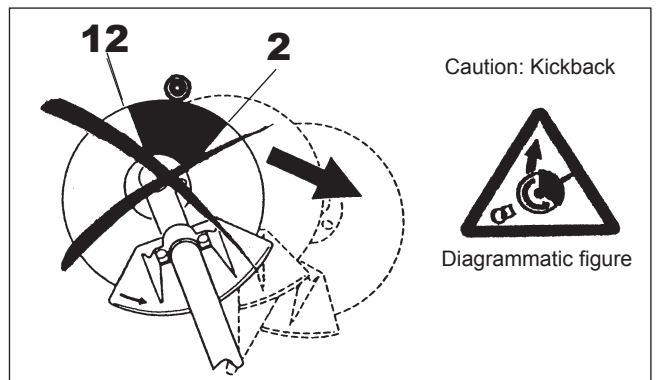

Kickback prevention

To avoid kickbacks, observe the following:

- Operation within the blade segment between 12 and 2 o'clock can cause serious potential hazards, especially when using metal cutting blades.
Use of this brushcutter utilizing blade segment positions from 11 to 12 o'clock and 2 to 5 o'clock can still cause a likely potential for some kickback.
- Cutting operations attempted within the blade segments between 11 and 12 o'clock, and between 2 and 5 o'clock, should only be performed by trained and experienced operators, and only at their own risk. Smooth and easy cutting with almost no kickback is possible using the blade segment between 8 and 11 o'clock.

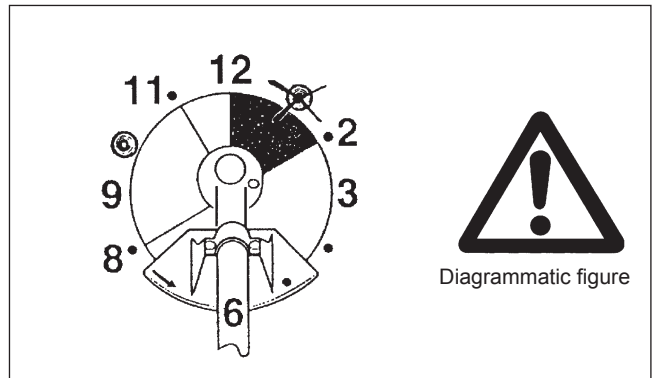

Cutting Tools

Use only the correct cutting tool for the specific job in hand.

Cutter blade (Star Blade (4 teeth), Eddy Blade (8 teeth)):

For cutting thick materials, such as weeds, high grass, bushes, shrubs, underwood, thicket, etc. (max. 2 cm dia. thickness). Perform this cutting work by swinging the brushcutter evenly in half-circles from right to left (similar to using a scythe).

Maintenance instructions

- The condition of the cutter, in particular of the cutter blade, guard and of the shoulder strap must be checked before commencing work. Particular attention is to be paid to the cutting blades which must be correctly sharpened.
- Turn off the engine and remove spark plug connectors when replacing or sharpening cutting blade, and also when cleaning the cutter or cutting tool.



Never straighten or weld damaged cutting blades.

- Be kind to the environment. Operate the brushcutter with as little noise and pollution as possible. In particular check the correct adjustment of the carburetor.
- Clean the brushcutter at regular intervals and check that all screws and nuts are securely tightened.
- Never service or store the brushcutter in the vicinity of open flames, sparks, etc.
- Always store the brushcutter in a well-ventilated locked room and with an emptied fuel tank.

Observe and follow all relevant accident prevention instructions issued by the trade associations and by insurance companies. Do not perform any modifications to the brushcutter as this will risk your safety.

The performance of maintenance or repair work by the user is limited to those activities described in this instruction manual. All other work is to be done by Authorized Service Agents. Use only genuine spare parts and accessories supplied by MAKITA. Use of non-approved accessories and tools means increased risk of accidents and injuries. MAKITA will not accept any liability for accidents or damage caused by the use of any non-approved cutting tools attachments or accessories.

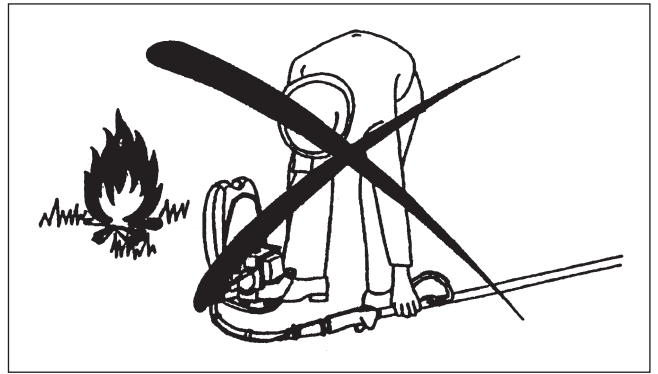

First Aid

In case of accident make sure that a well-stocked first-aid kit is available in the vicinity of the cutting operations. Immediately replace any item taken from the first aid box.

When asking for help, please give the following information:

- Place of accident
- What happened
- Number of injured persons
- Extent of injuries
- Your name



Packaging

The MAKITA brushcutter is delivered in two protective cardboard boxes to prevent shipping damage. Cardboard is a basic raw material and is therefore consequently reusable or suitable for recycling (waste paper recycling).



TECHNICAL DATA

Model	EBH340R	
	Loop handle	
Dimensions : length x width x height (without pipe case length)	mm	400 x 325 x 395
Mass (without guard and cutting blade)	kg	9.8
Volume (fuel tank)	L	0.65
Cutting attachments (cutter blade dia.)	mm	255
Engine displacement	cm ³	33.5
Maximum engine performance	kw	1.07 at 7,000 min ⁻¹
Engine speed at recommended max. spindle speed	min ⁻¹	10,000
Maximum spindle speed (corresponding)	min ⁻¹	7,500
Idling speed	min ⁻¹	3,000
Clutch engagement speed	min ⁻¹	4,100
Carburetor (Diaphragm - carburetor)	type	WALBRO WYL
Ignition system	type	Solid state ignition
Spark plug	type	NGK CMR6A
Electrode gap	mm	0.7 – 0.8
Fuel		Automobile gasoline
Engine oil		SAE 10W-30 oil API Classification, Class SF or higher (4-stroke engine for automobile)
Gear ratio		15/20

1) This data takes equally into account idling and full speed or wide open throttle operating modes.

DESIGNATION OF PARTS

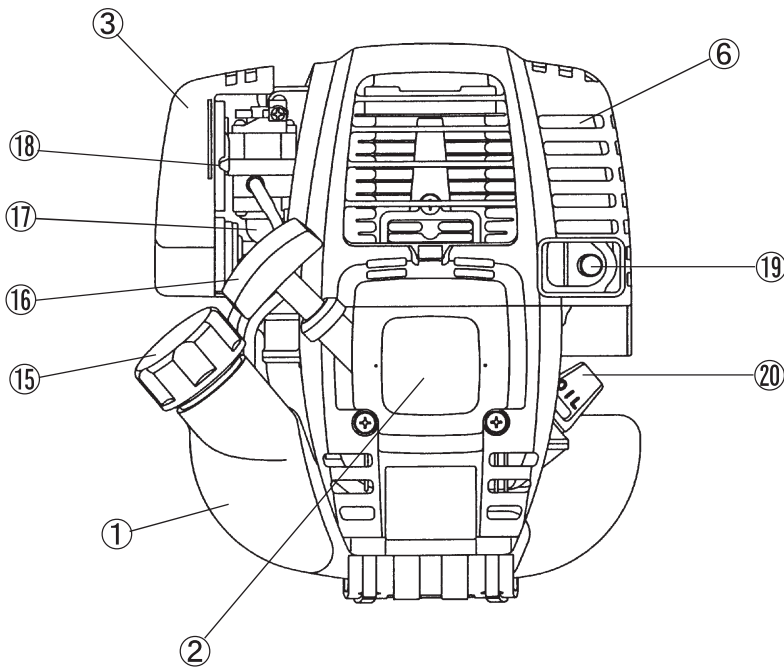
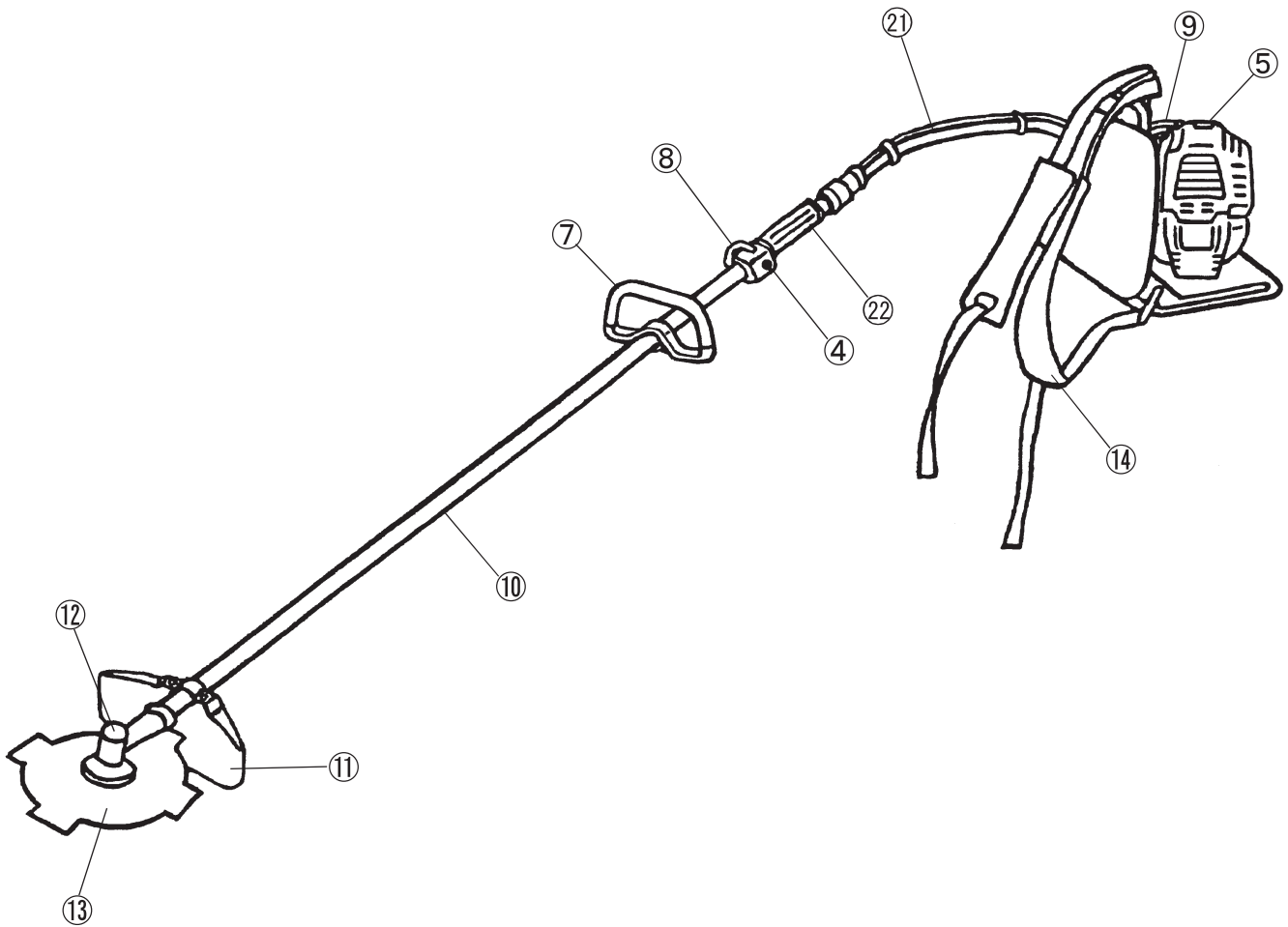

GB	DESIGNATION OF PARTS
1	Fuel Tank
2	Rewind Starter
3	Air Cleaner
4	I-O Switch (on/off)
5	Spark Plug
6	Exhaust Muffer
7	Handle
8	Control Lever
9	Control Cable
10	Shaft
11	Protector
12	Gear Case/Head Case
13	Cutter Blade
14	Shoulder Strap
15	Fuel Filter Cap
16	Starter Knob
17	Primer Pump
18	Choke Lever
19	Exhaust Pipe
20	Oil Gauge
21	Flexible Pipe
22	Grip

ASSEMBLY OF ENGINE AND DRIVE SHAFT



CAUTION: Before performing any work on the brushcutter, always switch off the motor and pull the spark plug connectors off the spark plug. Beware of hot engine parts and sharp blade edges. Always wear protective gloves!

CAUTION: Start the brushcutter only after having assembled it completely.

- 1. Joining flexible pipe with engine and pipe case holder**
 Insert one end of a flexible pipe (1) into a clutch housing (2) on an engine until it locks with a slight "click" noise. Insert the other end of the flexible pipe into a pipe case (3) holder of a brushcutter until it locks. Each end of the flexible pipe is interchangeable. Make sure that a square end of a flexible shaft fits into the joint of a drive shaft.

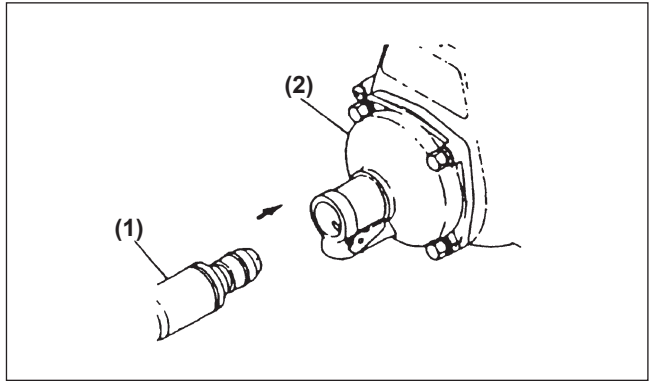

CAUTION: If you have difficulty to insert the flexible pipe properly, the square end of the flexible shaft may not fit the drive shaft joint. Do not force to push to avoid damage on the flexible shaft end. Repeat the same procedure again until flexible shaft and pipe fit properly.

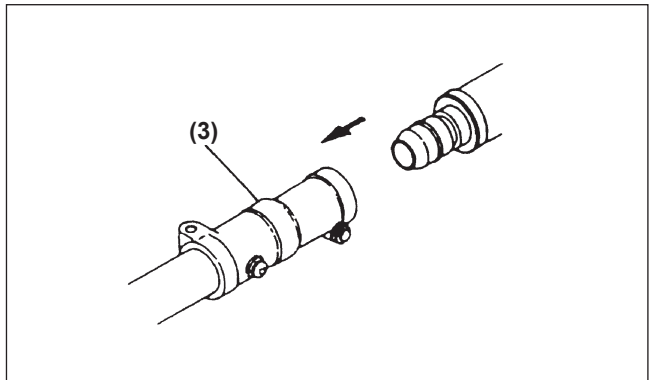

2. Mounting of control cable

- Remove the air cleaner cover.
- Place the control cable (4) in the adjusting bolt (5), and shift the swivel (6) so that the cable will be put in the swivel groove. At this time, the round-hole side of the swivel will be oriented toward the inner wire end-metal fitting.
- Release the swivel, and confirm that the inner wire-end metal fitting will be placed in the hole.
- Mount the air cleaner cover.

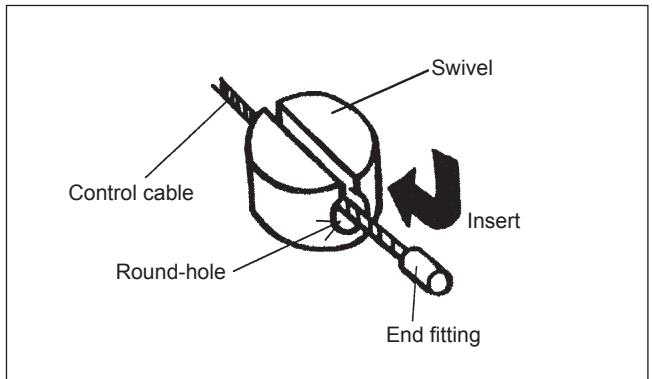
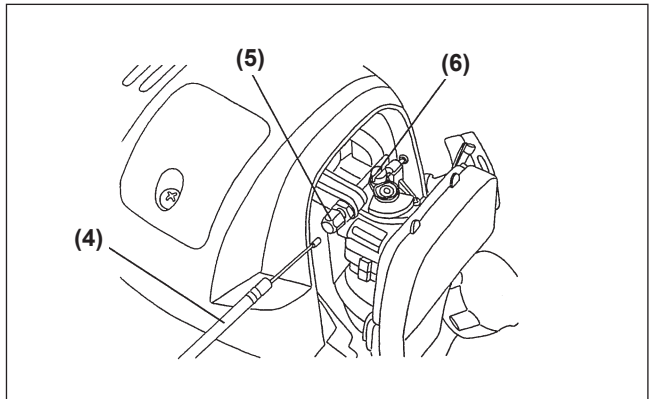

CONNECTION OF SWITCH CORD

- Connect the switch cords to the two cords from the engine by inserting one into the other.
- Fix the cord connector by clamp (7).

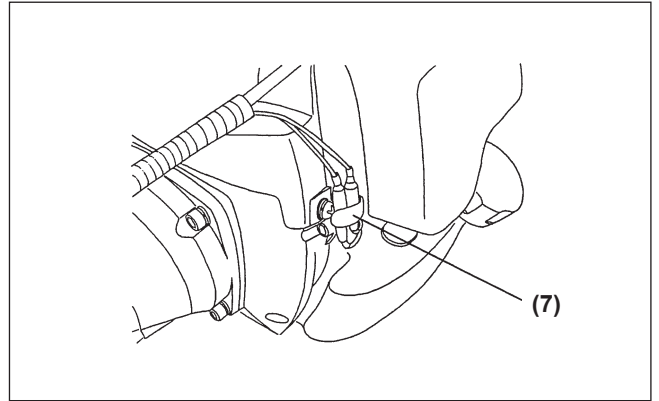

ADJUSTMENT OF CONTROL CABLE

- Adjust the control cable by adjusting bolt so that it will have 1 to 2 mm play when the throttle lever is set to the low-speed position by carburetor adjusting bolt. (Be careful that the cutter blade will not turn in idling.)

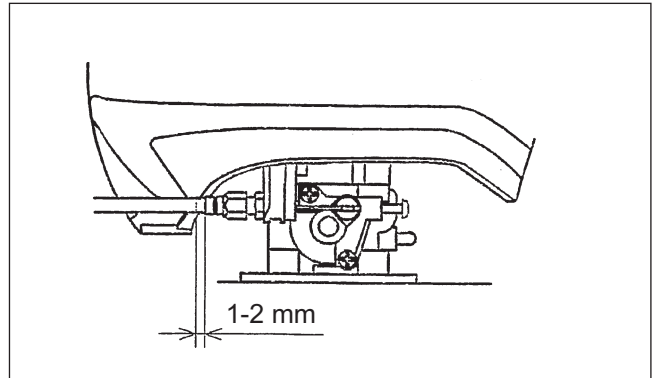

Make the throttle wire and I-O switch cords go along the flexible pipe and fix three point them on clip wire (8) tightly. If you do not fix the throttle wire and I-O switch cords surely, there is fear that they catch on the branch and so on it is dangerous.

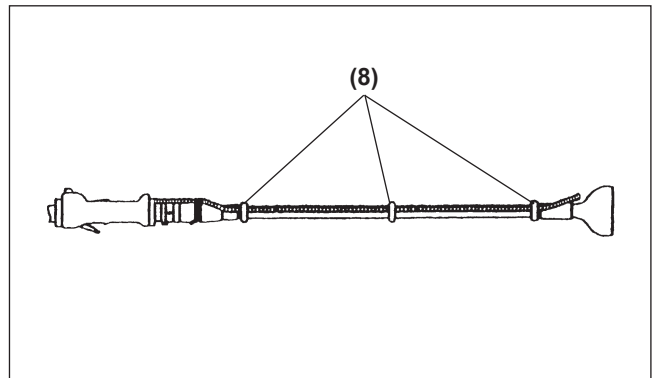

MOUNTING OF HANDLE

- Fix the loop handle to the drive shaft by 2 bolts firmly.
- Do not adjust position of the loop handle too close to the control grip. Keep not less than 25 cm distance between the handle and the grip.

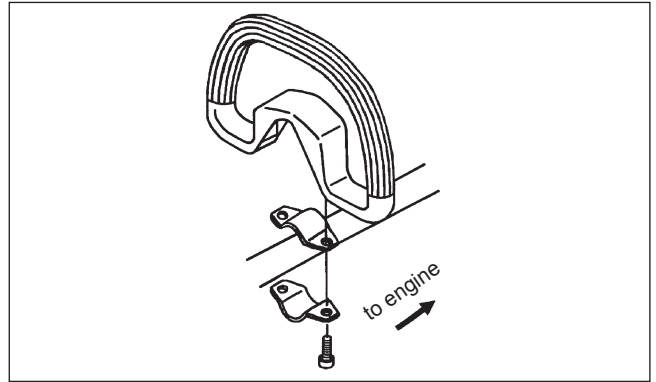

MOUNTING OF PROTECTOR

To meet the applicable safety provisions, only the tool/protector combinations as indicated in the table must be used. Failure to do so may result in serious injury or death to user or bystanders.

Be sure to use genuine MAKITA cutter blade.

- The cutter blade must be well clean, sharp and free of cracks or breakage.
If the cutter blade contacts any hard objects or stones during operation, stop the engine and check the blade immediately.
- Clean and sharpen or replace the cutter blade at least every three hours of operation.
- The outside diameter of the cutter blade must not exceed 255 mm (10-1/32"). Never use any blades surpassing 255 mm (10-1/32") in outside diameter.

CAUTION: The appropriate guard must always be installed, for your own safety and in order to comply with accident-prevention regulations. Operation of the equipment without the protector being properly in place must never be attempted.

- Fix protector to the drive shaft by 2 bolts firmly.
Never use a brushcutter without a protector or with a broken protector.

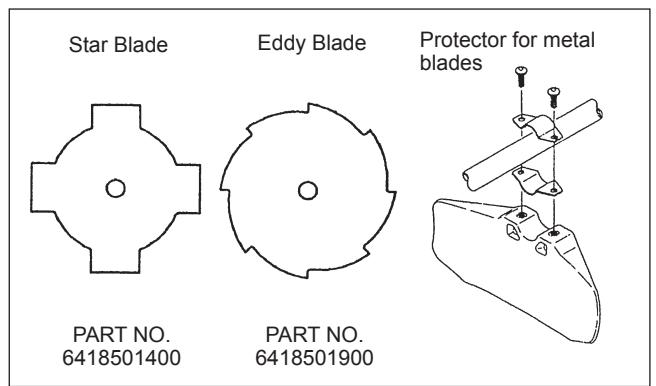

MOUNTING OF CUTTER BLADE

Turn the machine upside down, and you can replace the cutter blade easily.

- Fit a cutting blade and other parts in the order as in the illustration. Thrust a bar or allen wrench into a hole of the gear case until the cutting blade is locked and will not turn. Tighten a nut by turning to counter-clockwise with a combination wrench. (Note that the nut is tightened or loosened in the opposite direction of a usual nut.)
- The nut must be re-tightened every time before use.
- For this brushcutter, we recommend the cutting attachments on the right.
- Never attempt to cut a tree, a log, wood or other hard materials.

[Tightening torque: 28 - 48 N•m]

Note: Always wear gloves when handling the cutter blade.

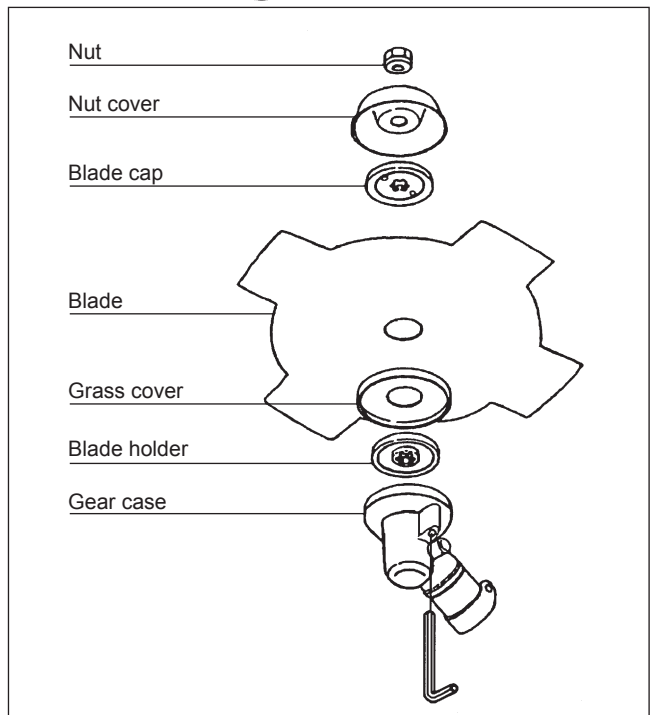

BEFORE START OF OPERATION



Inspection and Refill of Engine Oil

- Perform the following procedure, with the engine cooled down.
- While keeping the engine level, remove the oil gauge, and confirm that the oil is filled within the upper and lower limit marks.
- When the oil is in short in such a way that the oil gauge touches the oil only by its tip, in particular with the oil gauge remaining inserted in the crankcase without screwing-in (Fig. 1), refill new oil near the port (Fig. 2).
- For reference, the oil refill time is about 15 h (refill frequency: 15 times).
- If the oil changes in color or mixes with dirt, replace it with new one. (For the interval and method of replacement, refer to P 16)

Recommended oil: SAE 10W-30 oil of API Classification, Class SF or higher (4-stroke engine for automobile)

Oil volume: Approx. 0.1 L

Note: If the engine is not kept upright, oil may go into around the engine, and may be refilled excessively.

If the oil is filled above the limit, the oil may be contaminated or may catch fire with white.

Point 1 in Replacement of Oil “Oil Gauge”

- Remove dust or dirt near the oil refill port, and detach the oil gauge.
- Keep the detached oil gauge free of sand or dust. Otherwise, any sand or dust adhering to the oil gauge may cause irregular oil circulation or wear on the engine parts, which will result in troubles.
- As an example to keep the oil gauge clean, it is recommended to insert the oil gauge on its knob side into the engine cover, as shown in Fig. 3.

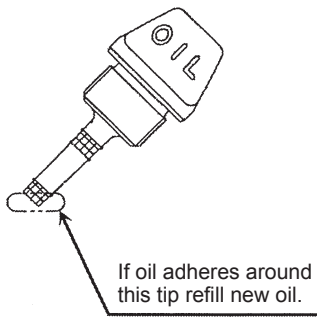

Fig. 1

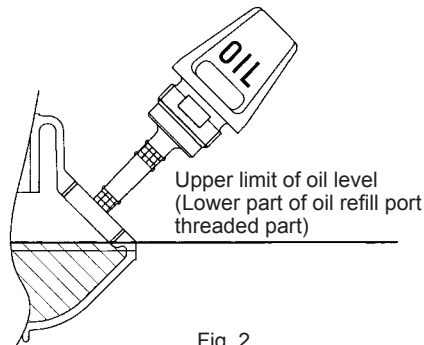

Fig. 2

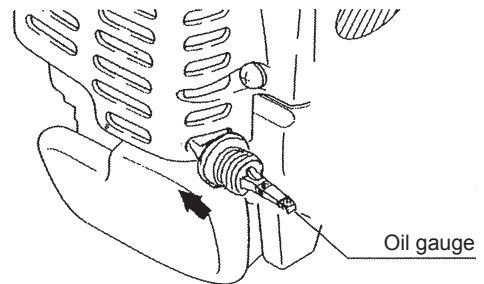
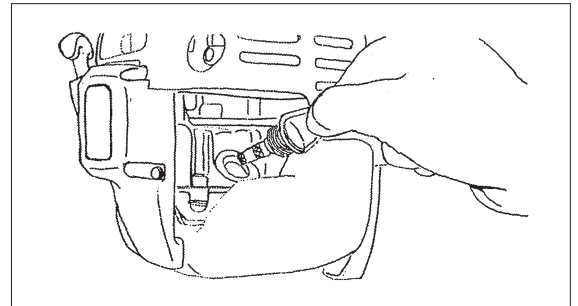
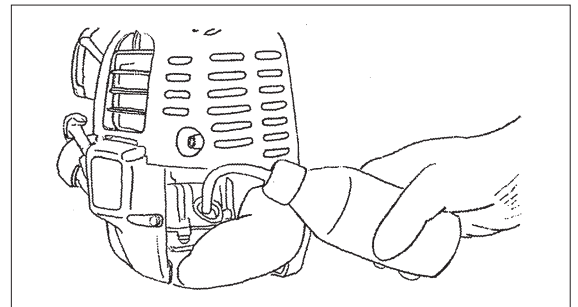

Fig. 3

- (1) Keep the engine level, and detach the oil gauge.



- (2) Fill oil up to the edge of the oil refill port. (Refer to Fig.2 of the preceding page).
Feed oil with the lubricant refill container.



- (3) Securely tighten the oil gauge. Insufficient tightening may cause oil leakage.

Point 2 in Replacement of Oil: “If oil spills out”

- If oil spills out between the fuel tank and engine main unit, the oil is sucked into through the cooling air intake port, which will contaminate the engine. Be sure to wipe out spilled oil before start of operation.

REFUELLING

Handling of Fuel

It is necessary to handle fuel with utmost care. Fuel may contain substances similar to solvents. Refuelling must be performed in a sufficiently ventilated room or in the open air. Never inhale fuel vapor, and keep fuel away from you. If you touch fuel repeatedly or for a long time, the skin becomes dry, which may cause skin disease or allergy. If fuel enters into the eye, clean the eye with fresh water. If your eye remains still irritated, consult your doctor.

Storage Period of Fuel

Fuel should be used up within a period of 4 weeks, even if it is kept in a special container in a well-ventilated shade. If a special container is not used or if the container is not covered, fuel may deteriorate in one day.

STORAGE OF MACHINE AND REFILL TANK

- Keep the machine and tank at a cool place free from direct sunshine.
- Never keep the fuel in the cabin or trunk.

Fuel

The engine is a four-stroke engine. Be sure to use an automobile gasoline (regular gasoline or premium gasoline).

Points for Fuel

- Never use a gasoline mixture which contains engine oil. Otherwise, it will cause excessive carbon accumulation or mechanical troubles.
- Use of deteriorated oil will cause irregular startup.

Refuelling

WARNING: INFLAMMABLES STRICTLY PROHIBITED

Gasoline Used: Automobile gasoline (unleaded gasoline)

- Loosen the tank cap a little so that there will be no difference in atmospheric pressure.
 - Detach the tank cap, and refuel, discharging air by tilting the fuel tank so that the refuel port will be oriented upward. (Never refill fuel full to the oil refill port.)
 - Wipe well the periphery of the tank cap to prevent foreign matter from entering into the fuel tank.
 - After refuelling, securely tighten the tank cap.
-
- If there is any flaw or damage on the tank cap, replace it.
 - The tank cap is consumable, and therefore should be renewed every two to three years.

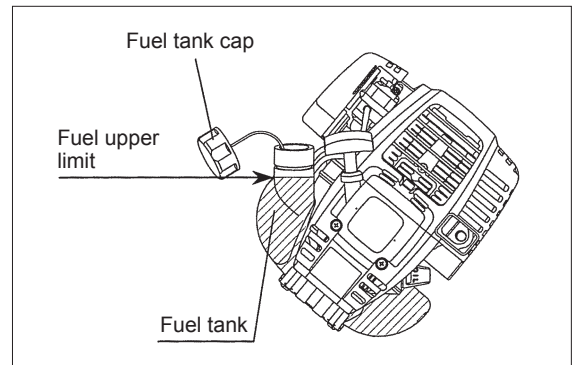

POINTS IN OPERATION AND HOW TO STOP

Observe all applicable accident prevention regulations!



STARTING

Move at least 3 m away from the place of refuelling. Place the brushcutter on a clean piece of ground taking care that the cutting tool does not come into contact with the ground or any other objects.

A: Cold start

- 1) Set this machine on a flat space.
- 2) Move the throttle lever (1) to the start position (Low speed).

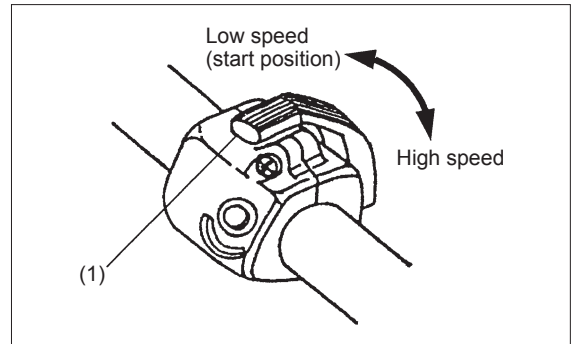

- 3) Choke lever
 - Close the choke lever.
 - Choke opening:
 - Full closing in cold or when the engine is cold.
 - Full or half opening in restart just after stop of operation.

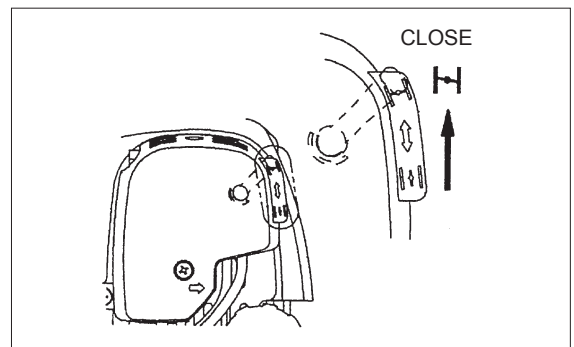

- 4) Primer pump
 - Continue to push the primer pump until fuel enters into the primer pump. (In general, fuel enters into the primer pump by 7 to 10 pushes.)
 - If the primer pump is pushed excessively, an excess of gasoline returns to the fuel tank.

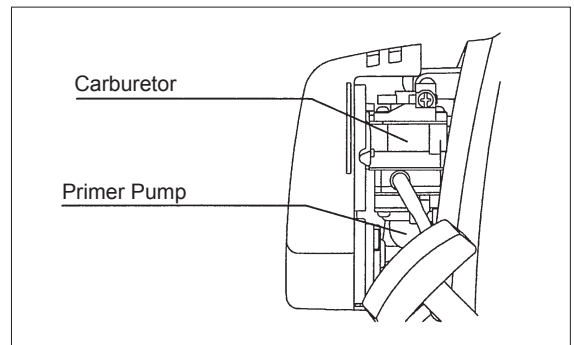

- 5) Recoil starter
 - Pull the start knob gently until it is hard to pull (compression point). Then, return the start knob, and pull it strongly.
 - Never pull the rope to the full. Once the start knob is pulled, never release your hand immediately. Hold the start knob until it returns to its original point.

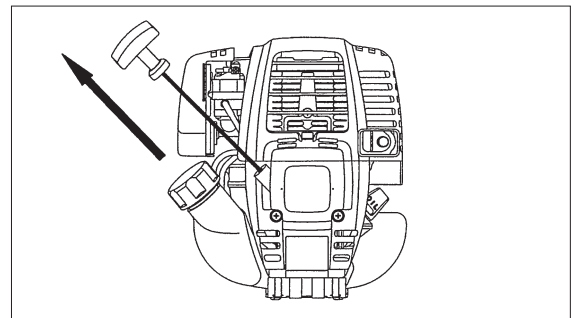

- 6) Choke lever
 - When the engine starts, open the choke lever.
 - Open the choke lever progressively while checking the engine operation. Be sure to open the choke lever to the full in the end.
 - In cold or when the engine is cooled down, never open the choke lever suddenly. Otherwise, the engine may stop.

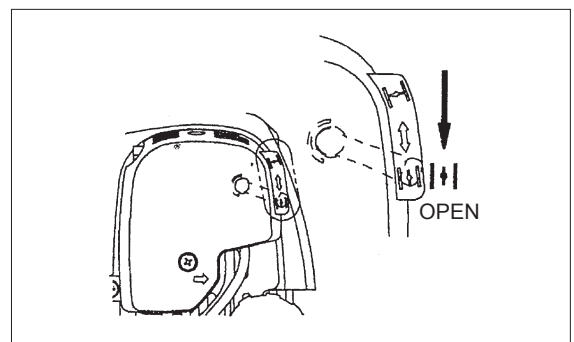

- 7) Warm-up operation
 - Continue warm-up operation for 2 to 3 minutes.

- Note: – If the starter handle is pulled repeatedly when the choke lever remains at “CLOSE” position, the engine will not start easily due to excessive fuel intake.
- In case of excessive fuel intake, remove the spark plug and pull the starter handle slowly to remove excess fuel. Also, dry the electrode section of the spark plug.

Caution during operation:

If the throttle lever is opened fully in a no-load operation, the engine rotation is increased to 10,000 rpm or more. Never operate the engine at a higher speed than required and at an approximate speed of 6,000 - 8,500 rpm.

B: Startup after warm-up operation

- 1) Push the primer pump repeatedly.
- 2) Keep the throttle lever at the idling position.
- 3) Pull the recoil starter strongly.
- 4) If it is difficult to start the engine, open the throttle by about 1/3.
Pay attention to the cutter blade which may rotate.

Attention in Operation

- When the engine is operated upside down, white smoke may come out from the muffler.

STOPPING

- 1) Reset the throttle lever (1) to the low speed position and slow down the engine rpm. Then, continue to depress the STOP switch (2) until the engine stops completely.
- 2) Be sure to confirm that the cutter blade is completely at a stop, as it may sometimes turn after the engine stops.

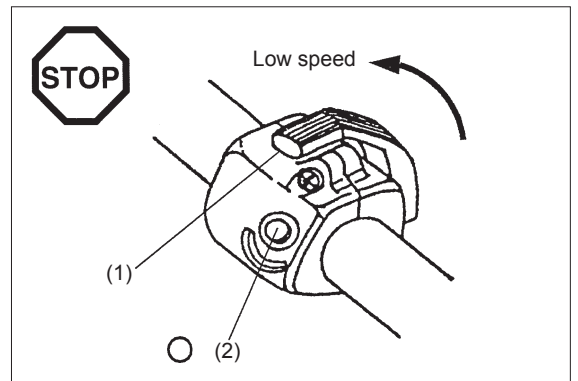

ADJUSTMENT OF LOW-SPEED ROTATION (IDLING)

When it is necessary to adjust the low-speed rotation (idling), perform it by the carburetor adjusting screw.

CHECKUP OF LOW-SPEED ROTATION

- Set the low-speed rotation to 3,000 min⁻¹.
- If it is necessary to change the rotation speed, regulate the adjusting screw (illustrated on the left), with Phillips screwdriver.
- Turn the adjusting screw to the right, and the engine rotation will increase. Turn the adjusting screw to the left, and the engine rotation will drop.
- The carburetor is generally adjusted before shipment. If it is necessary to readjust it, please contact Authorized Service Agent.

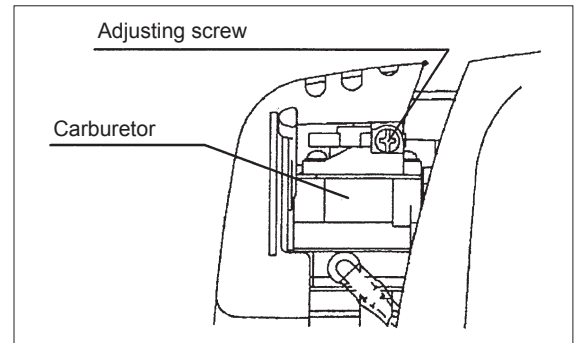

RESHARPENING THE CUTTER BLADE

CAUTION: The cutter blade mentioned below must only be resharpened by an authorized facility. Manual resharpening will result in imbalances of the cutting tool causing potentially dangerous vibrations and damage to the equipment.

- Cutter blade (Star blade (4 teeth), Eddy blade (8 teeth))
An expert resharpening and balancing service is provided by Authorized Service Agents.

Note: To increase the service life of the cutter blade (star blade, eddy blade) it may be turned over once, until both cutting edges have become dull. Never continue to use a dull blade or kickback and serious injury may result.

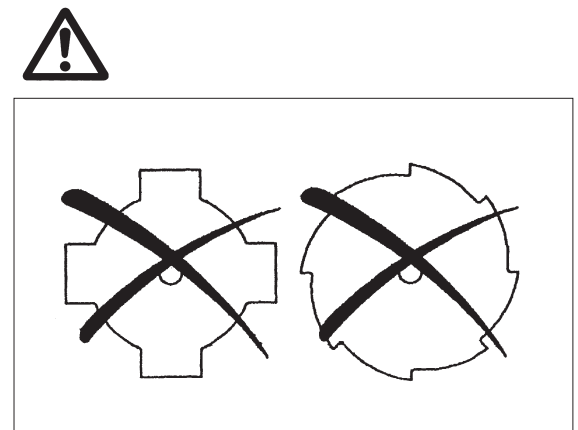

SERVICING INSTRUCTIONS



CAUTION: Before doing any work on the brushcutter, always stop the engine and pull the plug cap off the spark plug (see “checking the spark plug”).
Always wear protective gloves!

To ensure a long service life and to avoid any damage to the equipment, the following servicing operations should be performed at regular intervals.

Daily checkup and maintenance

- Before operation, check the machine for loose screws or missing parts. Pay particular attention to the tightness of the cutter blade or nylon cutting head.
- Before operation, always check for clogging of the cooling air passage and the cylinder fins. Clean them if necessary.
- Perform the following work daily after use:
 - Clean the brushcutter externally and inspect for damage.
 - Clean the air filter. When working under extremely dusty conditions, clean the filter the several times a day.
 - Check the blade or the nylon cutting head for damage and make sure it is firmly mounted.
 - Check that there is sufficient difference between idling and engagement speed to ensure that the cutting tool is at a standstill while the engine is idling (if necessary reduce idling speed).
If under idling conditions the tool should still continue to run, consult your nearest Authorized Service Agent.
- Check the functioning of the I-O switch, the lock-off lever, the control lever, and the lock button.

REPLACEMENT OF ENGINE OIL

Deteriorated engine oil will shorten the life of the sliding and rotating parts to a great extent. Be sure to check the period and quantity of replacement.



ATTENTION: In general, the engine main unit and engine oil still remain hot just after the engine is stopped. In replacement of oil, confirm that the engine main unit and engine oil are sufficiently cooled down. Otherwise, there may remain a risk of scald.

Note: If the oil filled above the limit, it may be contaminated or may catch fire with white smoke.

Interval of replacement: Initially, every 20 operating hours, and subsequently every 50 operating hours

Recommended oil: SAE10W-30 oil of API Classification SF Class or higher (4-stroke engine oil for automobile)

In replacement, perform the following procedure.

- 1) Confirm that the tank cap is tightened securely.
- 2) Detach the oil gauge.
Keep the oil gauge free from dust or dirt.

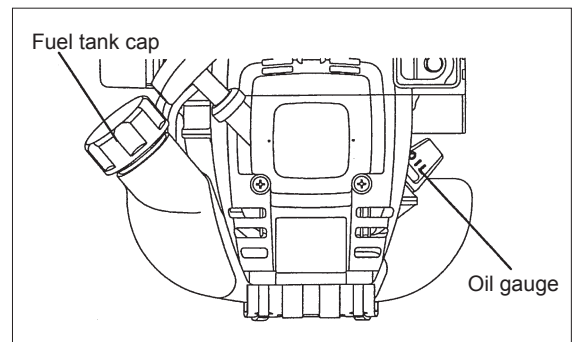

- 3) Place waste or paper near the oil refill port.

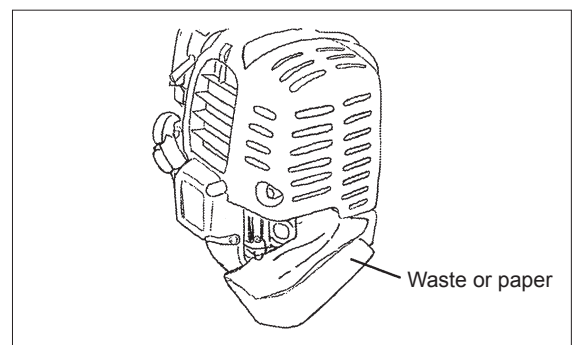

- 4) Detach the oil gauge, and drain oil, tilting the main unit toward the oil refill port.
Drain oil in a container.

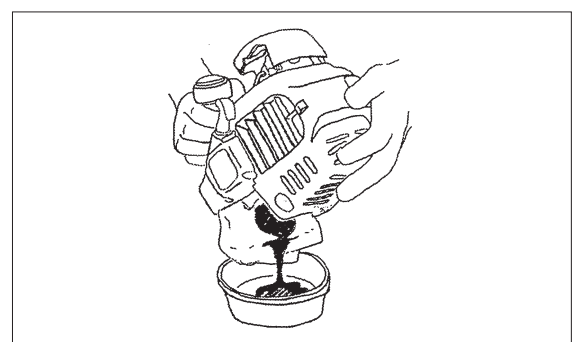

- 5) Keep the engine level, and feed new oil up to the edge of the oil refill port. In refill, use a lubricant refill container.
- 6) After refill, securely tighten the oil gauge. Insufficient tightening of the oil gauge will lead to oil leakage.

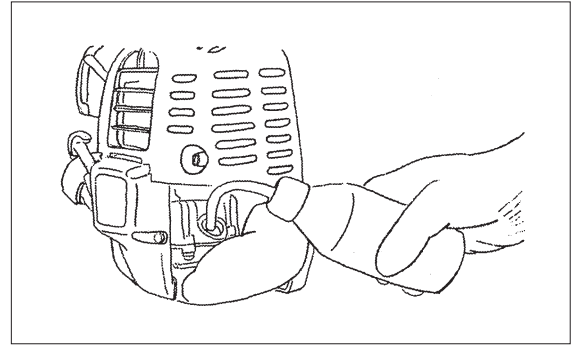

POINTS ON OIL

- Never discard replaced engine oil in garbage, earth or sewage ditch. Disposal of oil is regulated by law. In disposal, always follow the relevant laws and regulations. For any points remaining unknown, contact Authorized Service Agent.
- Oil will deteriorate even when it is kept unused. Perform inspection and replacement at regular intervals (replace with new oil every 6 months).

CLEANING OF AIR CLEANER



DANGER: INFLAMMABLES STRICTLY PROHIBITED

Interval of Cleaning and Inspection: Daily (every 10 operating hours)

- Turn the choke lever to the full close side, and keep the carburetor off from dust or dirt.
- Remove the air cleaner cover-fixing bolts.
- Pull the cover lower side and detach the air cleaner cover.
- If oil adheres to the element (sponge), squeeze it firmly.
- For heavy contamination:
 - 1) Remove the element (sponge), immerse it in warm water or in water-diluted neutral detergent, and dry it completely.
 - 2) Clean the element (felt) with gasoline, and dry it completely.
- Before attaching the element, be sure to dry it completely. Insufficient drying of the element may lead to difficult startup.
- Wipe out with waste cloth, oil adhering around the air cleaner cover and plate breather.
- Immediately after cleaning is finished, attach the cleaner cover and tighten it with fixing bolts. (In remounting, first place the upper claw, and then the lower claw.)

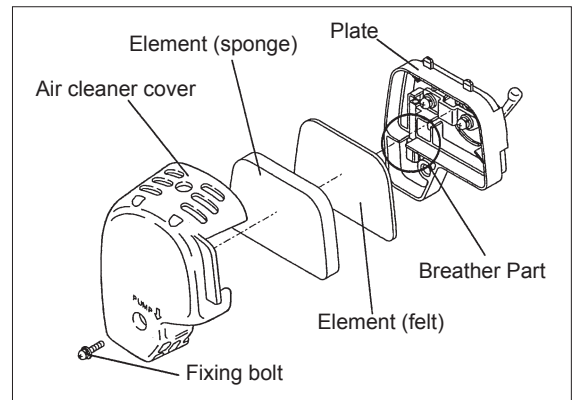

Points in Handling Air Cleaner Element

- Clean the element several times a day, if excessive dust adheres to it.
- If operation continues with the element remaining not cleared of oil, oil in the air cleaner may fall outside, resulting in oil contamination.

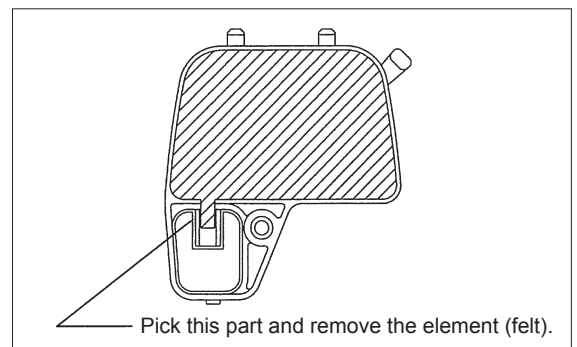

CHECKING THE SPARK PLUG

- Only use the supplied universal wrench to remove or to install the spark plug.
- The gap between the two electrodes of the spark plug should be 0.7 - 0.8 mm (0.028" - 0.032"). If the gap is too wide or too narrow, adjust it. If the spark plug is clogged with carbon or fouled, clean it thoroughly or replace it.

CAUTION: Never touch the spark plug connector while the engine is running (danger of high voltage electric shock).

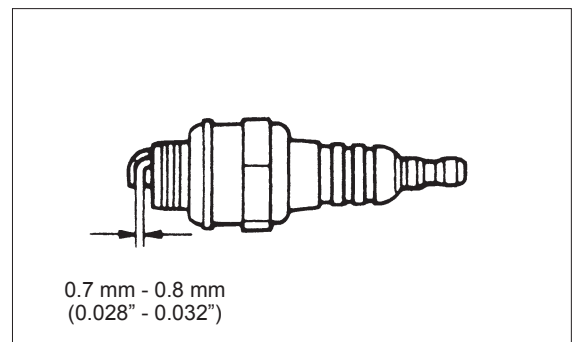

SUPPLY OF GREASE TO GEAR CASE

- Supply grease (Shell Alvania 2 or equivalent) to the gear case through the grease hole every 30 hours. (Genuine MAKITA grease may be purchased from your MAKITA dealer.)

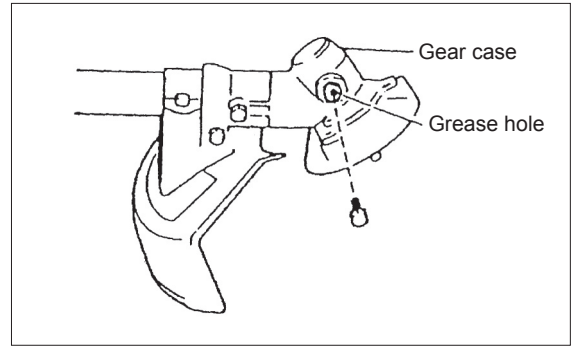

CLEANING OF FUEL FILTER

WARNING: INFLAMMABLES STRICTLY PROHIBITED

Interval of Cleaning and Inspection: Monthly (every 50 operating hours)

Suction head in the fuel tank

- The fuel filter (1) of the suction head is used to filter the fuel required by the carburetor.
- A periodical visual inspection of the fuel filter is to be conducted. For that purpose open the tank cap, use a wire hook and pull out the suction head through the tank opening. Filters found to have hardened, been polluted or clogged up are to be replaced.
- Insufficient fuel supply can result in the admissible maximum speed being exceeded. It is therefore important to replace the fuel filter at least quarterly to ensure satisfactory fuel supply to the carburetor.

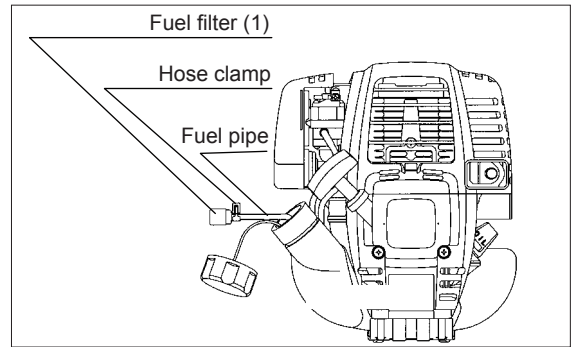

REPLACEMENT OF FUEL PIPE

CAUTION: INFLAMMABLES STRICTLY PROHIBITED

Interval of Cleaning and Inspection: Daily (every 10 operating hours)

Replacement: Annually (every 200 operating hours)

Replace the fuel pipe every year, regardless of operating frequency. Fuel leakage may lead to fire.

If any leakage is detected during inspection, replace the fuel pipe immediately.

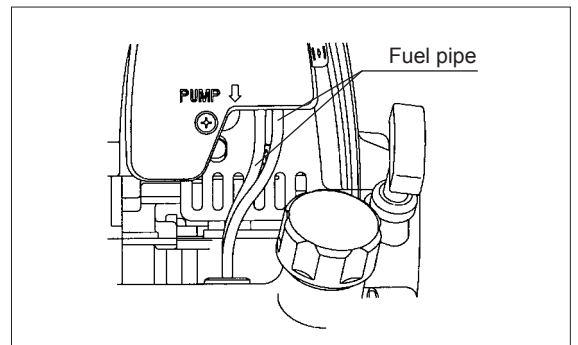

INSPECTION OF BOLTS, NUTS AND SCREWS

- Retighten loose bolts, nuts, etc.
- Check for fuel and oil leakage.
- Replace damaged parts with new ones for safety operation.

CLEANING OF PARTS

- Keep the engine always clean.
- Keep the cylinder fins free of dust or dirt. Dust or dirt adhering to the fins will cause seizure.

REPLACEMENT OF GASKETS AND PACKINGS

In reassembling after the engine is dismantled, be sure to replace the gaskets and packings with new ones.

SUPPLY OF GREASE TO THE FLEXIBLE SHAFT

- Pull out the flexible shaft from the flexible lining for every 20 hours, and apply grease on the flexible shaft.
- The flexible shaft may be broken if no grease is applied.

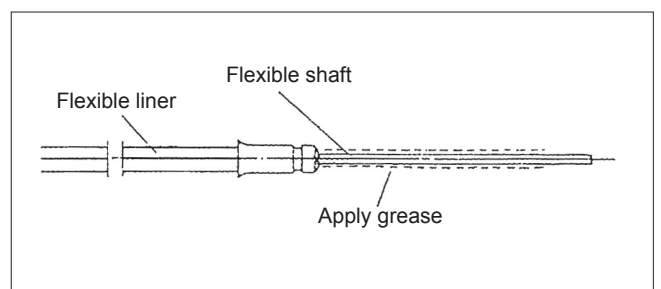

Any maintenance of adjustment work that is not been included and described in this manual is only to be performed by Authorized Service Agents.

STORAGE



WARNING: When draining the fuel, be sure to stop the engine and confirm that the engine cools down. Just after stopping the engine, it may still hot with possibility of burns, inflammability and fire.



ATTENTION: When the machine is kept out of operation for a long time, drain up all fuel from the fuel tank and carburetor, and keep it at a dry and clean place.

– Drain up fuel from the fuel tank and carburetor according to the following procedure:

- 1) Remove the fuel tank cap, and drain fuel completely.
If there is any foreign matter remaining in the fuel tank, remove it completely.
- 2) Pull out the fuel filter from the refill port using a wire.
- 3) Push the primer pump until fuel is drained from there, and drain fuel coming into the fuel tank.
- 4) Reset the filter to the fuel tank, and securely tighten the fuel tank cap.
- 5) Then, continue to operate the engine until it stops.

- Remove the spark plug, and drip several drops of engine oil through the spark plug hole.
- Gently pull the starter handle so that engine oil will spread over the engine, and attach the spark plug.
- Attach the cover to the cutter blade.
- Keep the drained fuel in a special container in a well-ventilated shade.

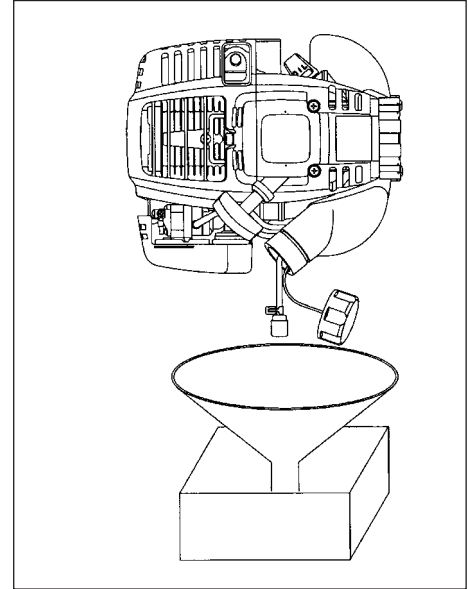

Attention after long-time storage

- Before startup after long-time shutdown, be sure to replace oil (refer to P 16). Oil will deteriorate while the machine is kept out of operation.

Fault location

Fault	System	Observation	Cause
Engine not starting or with difficulty	Ignition system	Ignition spark O.K.	Fault in fuel supply or compression system, mechanical defect
		No ignition spark	STOP-switch operated, wiring fault or short circuit, spark plug or connector defective, ignition module faulty
	Fuel supply	Fuel tank filled	Incorrect choke position, carburetor defective, fuel supply line bent or blocked, fuel dirty
	Compression	No compression when pulled over	Cylinder bottom gasket defective, crankshaft seals damaged, cylinder or piston rings defective or improper sealing of spark plug
Warm start problems	Mechanical fault	Starter not engaging	Broken starter spring, broken parts inside of the engine
		Tank filled ignition spark existing	Carburetor contaminated, have it cleaned
Engine starts but dies	Fuel supply	Tank filled	Incorrect idling adjustment, carburetor contaminated Fuel tank vent defective, fuel supply line interrupted, cable or STOP-switch faulty
Insufficient performance	Several systems may simultaneously be affected	Engine idling poor	Air filter contaminated, carburetor contaminated, muffler clogged, exhaust duct in the cylinder clogged

Item	Operating time								Shutdown/ rest	Corres- ponding P
		Before operation	After lubrication	Daily (10h)	30h	50h	200h			
Engine oil	Inspect/clean	○							12	
	Replace					○*1			16	
Tightening parts (bolt, nut)	Inspect	○							18	
Fuel tank	Clean/inspect	○							—	
	Drain fuel							○*3	19	
Throttle lever	Check function		○						15	
Stop switch	Check function		○						15	
Cutting blade	Inspect	○		○					11	
Low-speed rotation	Inspect/adjust			○					15	
Air cleaner	Clean			○					17	
Ignition plug	Inspect			○					17	
Cooling air duct	Clean/inspect			○					19	
Fuel pipe	Inspect			○					18	
	Replace						◎*2		—	
Gear-case grease	Refill				○				18	
Fuel filter	Clean/replace					○			18	
Oil tube	Inspect						◎*2		—	
Clearance between air intake valve and air discharge valve	Adjust						◎*2		—	
Engine overhaul							◎*2		—	
Carburetor	Drain fuel							○*3	19	

*1 Perform initial replacement after 20h operation.

*2 For the 200 operating hour inspection, request Authorized Service Agent or a machine shop.

*3 After emptying the fuel tank, continue to run the engine and drain fuel in the carburetor.

TROUBLESHOOTING

Before making a request for repairs, check a trouble for yourself. If any abnormality is found, control your machine according to the description of this manual. Never tamper or dismount any part contrary to the description. For repairs, contact Authorized Service Agent or local dealership.

State of abnormality	Probable cause (malfunction)	Remedy
Engine does not start	Failure to operate primer pump	Push 7 to 10 times
	Low pulling speed of starter rope	Pull strongly
	Lack of fuel	Feed fuel
	Clogged fuel filter	Clean
	Broken fuel tube	Straighten fuel tube
	Deteriorated fuel	Deteriorated fuel makes starting more difficult. Replace with new one. (Recommended replacement: 1 month)
	Excessive suction of fuel	Set throttle lever from medium speed to high speed, and pull starter handle until engine starts. Once engine starts, cutter blade starts rotating. Pay full attention to cutter blade. If engine will not start still, remove spark plug, make electrode dry, and reassemble them as they originally are. Then, start as specified.
	Detached plug cap	Attach securely
	Contaminated spark plug	Clean
	Abnormal clearance of spark plug	Adjust clearance
	Other abnormality of spark plug	Replace
	Abnormal carburetor	Make request for inspection and maintenance
	Starter rope cannot be pulled	Make request for inspection and maintenance
	Abnormal drive system	Make request for inspection and maintenance
Engine stops soon Engine speed does not increase	Insufficient warm-up	Perform warm-up operation
	Choke lever is set to "CLOSE" although engine is warmed up	Set to "OPEN"
	Clogged fuel filter	Clean
	Contaminated or clogged air cleaner	Clean
	Abnormal carburetor	Make request for inspection and maintenance
	Abnormal drive system	Make request for inspection and maintenance
Cutter blade does not rotate ↓ Stop engine immediately	Loosened cutter blade-tightening nut	Tighten securely
	Twigs caught by cutter blade or dispersion-preventing cover	Remove foreign matter
	Abnormal drive system	Make request for inspection and maintenance
Main unit vibrates abnormally ↓ Stop engine immediately	Broken, bent or worn cutter blade	Replace cutter blade
	Loosened cutter blade-tightening nut	Tighten securely
	Shifted convex part of cutter blade and cutter blade support fitting	Attach securely
	Abnormal drive system	Make request for inspection and maintenance
Cutter blade does not stop immediately ↓ Stop engine immediately	High idling rotation	Adjust
	Detached throttle wire	Attach securely
	Abnormal drive system	Make request for inspection and maintenance
Engine does not stop ↓ Run engine at idling, and set choke lever to CLOSE	Detached connector	Attach securely
	Abnormal electric system	Make request for inspection and maintenance

When the engine does not start after warm-up operation:

If there is no abnormality found for the check items, open the throttle by about 1/3 and start the engine.

Makita Corporation

www.makita.com

885214-0

ALA